

# Flexural Strength and Flexural Modulus of Fiber-Reinforced, Soft Liner–Retained Implant Overdenture

Mona Gibreel, DDS, MSD

Department of Biomaterials Science, Turku Clinical Biomaterials Centre (TCBC), Institute of Dentistry, University of Turku, Turku, Finland.

Lippo V. J. Lassila, DDS, PhD

TCBC, Institute of Dentistry, University of Turku, Turku, Finland.

Timo O. Närhi, DDS, PhD

Department of Prosthetic Dentistry and Stomatognathic Physiology, University of Turku, Turku, Finland; City of Turku, Welfare Division, Turku, Finland.

Leila Perea-Lowery, DDS, PhD

Department of Biomaterials Science, TCBC, Institute of Dentistry, University of Turku, Turku, Finland.

Pekka K. Vallittu, CDT, DDS, PhD

Department of Biomaterials Science, University of Turku, Turku, Finland; City of Turku, Welfare Division, Turku, Finland.

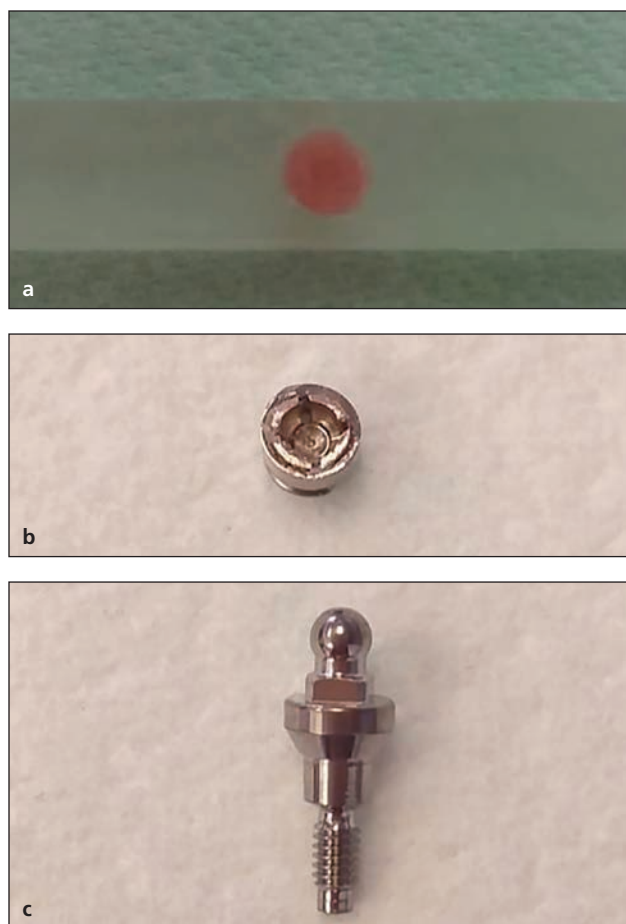
**Purpose:** To compare the flexural strength and modulus of ball-soft liner–retained overdentures vs ball-socket–retained overdentures, as well as to evaluate the effect of using glass fiber reinforcement on the mechanical properties of ball-soft liner–retained overdentures. **Materials and Methods:** A total of 80 overdenture specimens were fabricated and divided equally into four groups ( $n = 20/\text{group}$ ): specimens with a metal matrix (group 1); a silicone soft liner matrix (group 2); reinforced with one bundle of unidirectional Stick glass fiber placed above the silicone soft liner matrix (group 3); and reinforced with four weaves of bidirectional Stick Net glass fibers placed above the silicone soft liner matrix (group 4). Half of the specimens from each group were stored in water at room temperature ( $23^{\circ}\text{C} \pm 1^{\circ}\text{C}$ ) for 24 hours, while the other half were stored in water at  $37^{\circ}\text{C}$  for 30 days before being subjected to a static three-point loading test. **Results:** After 1 day of water storage, the flexural strength and flexural modulus values of groups 1, 3, and 4 were not significantly different from each other ( $P = .788$ ,  $P = .084$ ), but were significantly higher than group 2 ( $P < .05$ ). Water storage for 30 days significantly decreased the flexural strength of group 1 only ( $P < .001$ ) and not the other three groups ( $P > .05$ ). **Conclusion:** Overdentures retained with a metal matrix were not significantly different from those retained with a silicone soft liner matrix in terms of flexural strength and modulus after 30 days of water storage. Placing unidirectional and bidirectional glass-fiber reinforcement above soft liner matrices can increase the flexural strength of ball-soft liner–retained overdentures. *Int J Prosthodont* 2021;34:801–XX. doi: 10.11607/ijp.6677

Implants can be used in combination with attachments to promote the retention and stability of overdentures in completely edentulous patients. An overdenture supported by two dental implants placed bilaterally in the canine area has been considered as the gold standard for patients with complete edentulism.<sup>1</sup> Also, a single implant placed in the midline of the mandible has been reported to be effective.<sup>2–4</sup>

A variety of attachment systems are available and divided into two main categories: (1) splinted bar and (2) solitary stud attachments.<sup>5</sup> Solitary ball attachments provide higher stability and distribute the load more evenly and bilaterally to the residual ridge.<sup>6,7</sup> However, the wear of the metal matrix results in a decrease in retention. When the implants are not parallel, the male component can be abraded.<sup>8</sup> The contact between ball and socket during function generates a fulcrum line for overdenture rotation, which tends to generate tensile stresses within the denture base on the top surface of the abutment.<sup>9</sup>

**Correspondence to:**  
Dr Mona Gibreel  
TCBC, Institute of Dentistry,  
University of Turku  
Itäinen Pitkäkatu 4 B, FI-20520  
Turku, Finland.  
Email: mona.f.gibreel@utu.fi

Submitted August 14, 2019;  
accepted April 28, 2020.  
©2021 by Quintessence  
Publishing Co Inc.



**Fig 1** Attachment system and matrix used in testing procedures. (a) Silicone-based soft liner matrix. (b) Metallic matrix. (c) Ball abutment.

The use of a resilient silicone soft liner instead of the metal matrix of a ball attachment has been found to significantly reduce stress on the peri-implant tissues.<sup>10</sup> Moreover, it can be considered as an alternative treatment option when the number, angulation, or location of implants differs from what was originally planned. Another reason for consideration of such an attachment might be the quality of bone when implants are placed in grafted bone or in bone of poor quality. The patient's financial needs might play a role in the attachment selection when a simpler and cheaper design is preferred, as soft liner-retained overdentures need less prosthetic maintenance.<sup>11,12</sup> Placing a soft liner material around the implant abutment compensates for the volumetric contraction of the denture base resin, which happens during processing. Therefore, it prevents the abutments from coming into direct contact with the acrylic resin and decreases the possibility of implant overloading.<sup>13</sup> Due to their viscoelastic properties, soft liners distribute masticatory loads between the implant and the residual ridge,<sup>14</sup> reducing the need for prosthetic maintenance<sup>12,15</sup> and decreasing the incidence of peri-implant soft tissue complications.<sup>12,16</sup> They have acceptable bond strength values

to the acrylic resin, which can be enhanced in different ways, including the application of a primer. In contrast, a metal housing is retained on the denture base resins by mechanical means of retention.<sup>17,18</sup> Long-term silicone soft liners can last for up to 1 year.<sup>19</sup>

Attachment components need extra space for accommodation within the denture base, making it weaker and more prone to fracture, especially as the bite force increases.<sup>8,9</sup> The dimensions of the housings should be considered because a decrease in denture base thickness can increase the fracture potential.<sup>20,21</sup> The incidence of fracture is common in areas of high stress concentration, which is thought to be around the metal housing.<sup>21</sup> In addition, the bond strength between the denture base material and the metal housing, or between the orientation material and the metal housing, is another factor that can affect the flexural load and strength of the overdenture base.<sup>22,23</sup>

The use of glass fiber reinforcement above the implant abutment has been proven to increase the flexural strength and fatigue resistance of implant-retained overdentures.<sup>24–26</sup> Glass fibers perform better than metal reinforcement in terms of esthetics and chemical bonding to the resin matrix with the aid of a silane coupling agent.<sup>27,28</sup> They are available in various forms, such as continuous unidirectional rovings, continuous bidirectional weaves, or chopped fibers.<sup>29–31</sup>

To the present authors' knowledge, no studies evaluating the mechanical properties of ball-soft liner-retained overdentures have been published. The soft liner matrices may require more space within the overdenture base than a thin metal housing, making the denture base weaker. However, soft liners are more resilient, distribute occlusal loads in a different way, and bond differently to the denture base resin.<sup>17,32</sup>

Therefore, this study was set out to compare the flexural strength and flexural modulus of ball-soft liner-retained overdentures vs ball-socket-retained overdentures, as well as to evaluate the effect of using glass fiber reinforcement on the mechanical properties of ball-soft liner-retained overdentures. The study hypotheses were that there would be a difference in the investigated mechanical properties between overdentures retained with a soft liner matrix and those retained with a metal matrix and that using glass fiber reinforcement would improve the investigated mechanical properties of ball-soft liner-retained overdentures.

## MATERIALS AND METHODS

The study design used simulated overdenture specimens. Eighty specimens (65 mm long, 5 mm high, and 10 mm wide) were fabricated from clear autopolymerizing denture base resin (Palapress, Kulzer). The powder to liquid ratio of the autopolymerizing resin was 10 g: 7.0 mL, as

recommended by the manufacturers' instructions. The ball stud attachments selected for this study consisted of a metal matrix (3.1 mm in height × 3.6 mm in diameter; Dalbo-PLUS female part TE basic, Cendres+Métaux) and a ball abutment (ball diameter 2.25 mm, collar height 2 mm; Octa closed, Dyna Dental Engineering). Polyvinyl siloxane (PVS) soft lining material (Reline II Soft, GC) was used for fabricating the soft liner matrices (Fig 1).

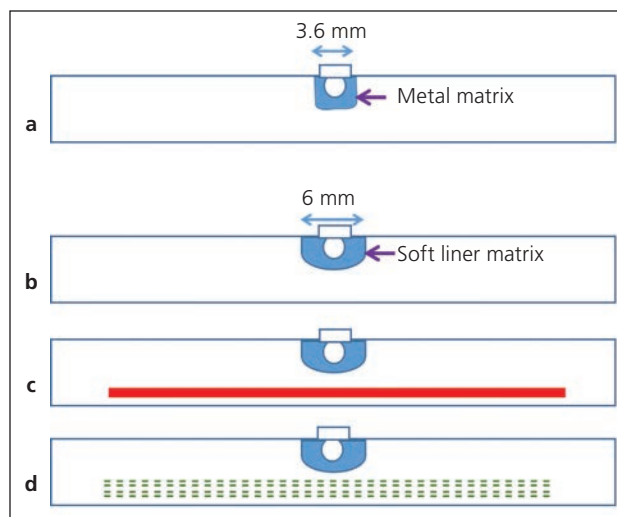
Fiber reinforcements in the form of bidirectional weaves (StickNET, GC) and unidirectional rovings (Stick, GC) were used in this study. Both are silanated E-glass fibers impregnated with porous polymethyl methacrylate (PMMA).

The test specimens were divided into four groups (n = 20/group) as follows: group 1 included overdenture specimens with a metal matrix in the middle (n = 20); group 2 included overdenture specimens with a silicone soft liner matrix (n = 20); group 3 included overdenture specimens reinforced with one roving of Stick glass fibers placed above the silicone soft liner matrix; and group 4 included overdenture specimens reinforced with four weaves of StickNET (SN) placed above the silicone soft liner matrix, as recommended by previous studies<sup>24,25</sup> (Fig 2).

In group 1 specimens, the metal matrix was placed centrally in a PVS laboratory putty mold (Lab Putty, Coltène; 5.2 × 10.2 × 65.2 mm<sup>3</sup>), and a mixture of acrylic resin was then poured to fill the mold. In the other three groups, a silicone mold with the same dimensions and a mid-projection (3.1 mm high × 6 mm wide) was used to keep a standardized space for soft liner placement within the finished specimen. In group 3, Stick fiber rovings were cut into equal lengths (60 mm), wetted for approximately 10 minutes with a thin powder-liquid mixture of autopolymerizing acrylic resin (Palapress, Kulzer) between two plastic sheets, placed within the mold after filling it with 4 mm of the acrylic resin mixture, and finally covered with the rest of the mixture up to the top of the mold. In group 4, SN fiber weaves were cut with scissors into layers of 60-mm length and 9-mm width, wetted, and placed in the same way as the unidirectional fibers. The specimens were then covered using glass plates and polymerized in distilled water maintained at 55°C ± 2°C under air pressure of 300 kPa for 15 minutes in a pneumatic polymerizing unit (Ivomat IP3, Ivoclar Vivadent).

The specimens were wet-ground with successively finer grades of silicon carbide abrasive papers from P500 to P1200 (LaboPol-21, Struers) to the predetermined dimensions (5 × 10 × 65 mm<sup>3</sup>).

After curing and polishing specimens in groups 2, 3, and 4, a primer (Reline II Primer, GC) was spread on the mid-hole within each specimen, followed by a mix of soft liner, and the entire specimen was placed over a ball abutment fixed to an acrylic model and allowed to set for 5 minutes. Excess soft liner material was removed



**Fig 2** Schematic view of test groups of ball-retained overdenture specimens according to matrix material and reinforcement. (a) Group 1. (b) Group 2. (c) Group 3. (d) Group 4. Red lines represent the unidirectional fiber bundle, and green lines represent bidirectional fiber weaves.

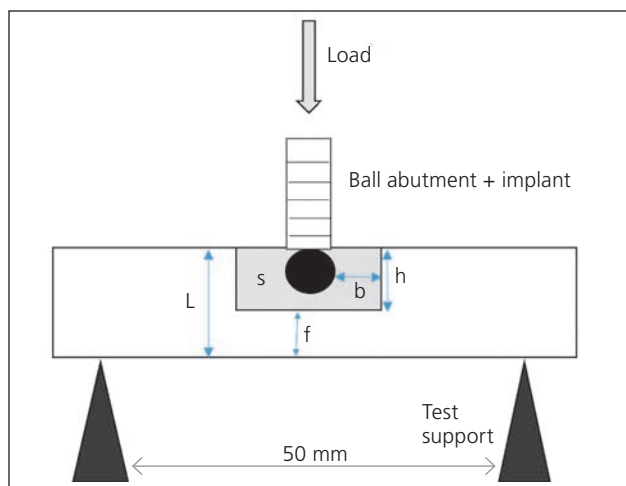
with a scalpel. The finalized specimen had a silicone soft liner housing 1.88 mm thick bilaterally on both sides of the ball abutment.

Half of the specimens from each group were stored in water at room temperature (23°C ± 1°C) for 24 hours, while the other half were stored in water at 37°C for 30 days before testing. A static three-point loading test was performed to determine the flexural strength and flexural modulus values of the test groups using a universal testing machine (LRX, Lloyd Instruments). The test speed was adjusted to 5 mm/minute while using the implant (3.6-mm diameter and 11.5-mm length; Helix Art Octa Implants, Dyna Dental Engineering) with the ball abutment for load application (Fig 3). The distance between the supports of the test specimens was 50 mm. The maximum load values exerted at failure were recorded in Newtons (N). Elastic modulus values (GPa) were collected from the machine. Flexural strength (FS) was then calculated from the following equation<sup>33</sup>:

$$\text{Flexural strength (MPa)} = 3PL/2bd^2$$

In the formula, P = maximum load (N), L = span length (50 mm), b = specimen width (10 mm), and d = specimen thickness (5 mm). After the loading test, specimens were visually examined to detect the failure modes.

The surface fractures of representative specimens were evaluated using scanning electron microscopy (SEM; JSM-5500, Jeol). The selected specimens were wet-ground (LaboPol-21) with silicon carbide papers of decreasing abrasiveness (1,000-, 1,200-, 4,000-grit) and then gold-sputter coated for the SEM examination. Additionally, the fractured surfaces and bonding interphase



**Fig 3** Schematic view of three-point loading testing procedure. *S* = matrix made of silicone-based soft liner; *L* = 5 mm; *f* = 1.9 mm; *h* = 3.1 mm; *b* = 1.88 mm in thickness.

between the soft liner and denture base resin before and after water storage were examined with SEM.

Data were collected, and a 3-way analysis of variance (ANOVA) was conducted to detect the effect of matrix material, reinforcement, and water storage duration as the independent variables on the evaluated properties ( $\alpha = .05$ ). Statistical analysis of the flexural strength and flexural modulus values for the test groups was then carried out with 1-way ANOVA and Tukey multiple comparisons post hoc analysis ( $\alpha = .05$ ). All analyses were conducted using statistical software (SPSS version 21, IBM).

## RESULTS

The mean values for flexural strength and flexural modulus of the tested groups are presented in Table 1. The matrix material, water storage duration, and reinforcement significantly affected the flexural strength and flexural modulus values of the test groups ( $P < .05$ ). The interaction between the matrix material and storage was significant ( $P = .018$  and  $P = .024$ , respectively) while that between storage and reinforcement was not significant ( $P = .236$  and  $P = .053$ , respectively).

One-way ANOVA revealed a statistically significant difference in the mean flexural strength and flexural modulus values among the tested groups ( $P < .001$ ). After 1 day of water storage, the mean flexural strength and flexural modulus values of groups 1, 3, and 4 were not significantly different from each other ( $P = .788$  and  $P = .312$ , respectively), but were significantly higher than group 2 ( $P < .05$ ; Tukey post hoc analysis). After water storage for 30 days, the mean flexural strength value of group 3 was significantly higher than groups 1 and 2 ( $P < .001$ ), while the flexural modulus values were not significantly different ( $P = .065$ ). Moreover, the flexural

strength of group 4 was significantly higher than that of group 2 only ( $P = .003$ ). Water storage for 30 days significantly decreased the flexural strength of group 1 ( $P < .001$ ), but not the other three groups ( $P > .05$ ).

The fracture modes are presented in Table 2. Visual examination revealed that all of the specimens in groups 1, 2, and 4 were completely fractured. In group 3, only 3 specimens were partially fractured, and the fracture line was arrested at the fibers (Fig 4). Fractured surfaces of the tested groups are shown in Figs 5 to 8. SEM examination of the bonding interphase between the soft liner and denture base resin showed good adaptation of the soft liner to the resin surface without separation (Fig 9).

## DISCUSSION

The results confirmed the study hypotheses, since there was a difference in the investigated mechanical properties between overdentures retained with a soft liner matrix and those with a metal matrix, and using glass fiber reinforcement improved the flexural strength of ball-soft liner-retained overdentures.

A silicone soft liner matrix has viscoelastic properties that can compensate for the difference in resiliency between the mucous membrane and the implants. This is accomplished by enabling the denture movement to be consistent with the mucous membrane and transmitting a part of the occlusal load to the residual ridge.<sup>14,34</sup> They have been associated with minimal wear, less prosthetic complications, and better peri-implant soft tissue health.<sup>12,15</sup>

Two main groups of resilient denture liners are available: plasticized acrylic resin and silicone rubber, which can be either autopolymerized or heat-cured. Silicone-based relining materials are not affected to a high extent by aging, in contrast to acrylic resin-based ones, which show permanent deformation and a loss of cushioning effect due to continued polymerization and/or a plasticizer loss.<sup>35</sup> They are more retentive, durable, and respond to load application and removal very quickly.<sup>35-37</sup> Therefore, a silicone-based soft liner material was selected for this study.

A bilateral 2-mm-thick layer of silicone-based soft liner with hardness  $< 90$  was found to be effective in distributing and reducing stresses transmitted from the denture base to the implant-supporting structures.<sup>10</sup> The soft liner thickness applied in the present study was 1.88 mm on each side.

The present study showed that water storage duration had a significant effect on the flexural strength values. Although the flexural strength and flexural modulus values of group 1 (with metal matrix for a ball attachment) were not significantly different from groups 3 and 4 after 24 hours of water storage, it was the only group that showed a significant reduction in the flexural strength

after water storage for 30 days. A study conducted by Yoshida et al<sup>38</sup> showed that the flexural strength of bulk denture base resin was significantly decreased, while that of reinforced denture base resins did not change after 180 days of water immersion. This was attributed to the leaching of soluble components (such as unreacted monomers and plasticizers<sup>39,40</sup>) and the resulting formation of microvoids that are filled with water by inward diffusion, which adversely affects the polymer strength by facilitating the polymer chains movement.<sup>41</sup> On the other side, using properly impregnated glass fiber reinforcement that bonds chemically to the acrylic resin denture base can enhance its mechanical properties even after long-term water immersion and reduce its water sorption.<sup>42</sup>

The matrix material significantly affected the tested mechanical properties, as shown by the 3-way ANOVA. Group 2 had the lowest flexural strength and modulus values under both storage conditions. This might be attributed to the difference in the elastic modulus between metal and silicone resilient liners.<sup>35</sup> Another cause might be the diameter of the silicone soft liner within the overdenture base, which was 2.4 mm bigger than that of the metal matrix.<sup>26</sup>

In contrast to group 1, the flexural strength values of the other three groups with soft liner matrices were not affected by water storage. This could be explained by the difference in resiliency between the metal and soft liner matrices, which might affect the load transmission.<sup>35</sup> The lack of vertical resiliency, as well as the contact between ball and metal socket, cause denture rotation during loading and generate tensile stresses within the denture base above the abutment.<sup>9,43</sup> Another cause would be the effect of acrylic resin polymerization shrinkage at the resin-metal interface. This shrinkage tends to generate residual stresses at the interface, causing the resin to pull away from the rigid metal, increasing the risk of bond failure and allowing for the influx of oral fluids and material degradation.<sup>44</sup> On the other hand, silicone soft liners are viscoelastic materials with cushioning ability, which can compensate for the volumetric contraction and maintain adequate bonding with the denture base resin.<sup>13</sup> They can absorb and distribute functional stresses more evenly, rather than concentrating them within certain areas.<sup>32,45</sup> A previous study showed that those viscoelastic properties were not affected after 3 years of water storage.<sup>46</sup> The high filler content of the used soft liner might have decreased the water sorption and solubility.<sup>35</sup> Moreover, the bonding strength between the matrix and the denture base<sup>22,23</sup> might have played a role since it was mechanical for the metal matrix, while a primer was used to enhance the bond strength<sup>47</sup> of the silicone soft liner to the denture base. Besides, the compliance of the soft liner<sup>48</sup> used in this study might have affected the bond strength. Increasing the filler

**Table 1** Mean  $\pm$  SD Flexural Strength (FS) and Flexural Modulus (FM) Values of the Tested Groups

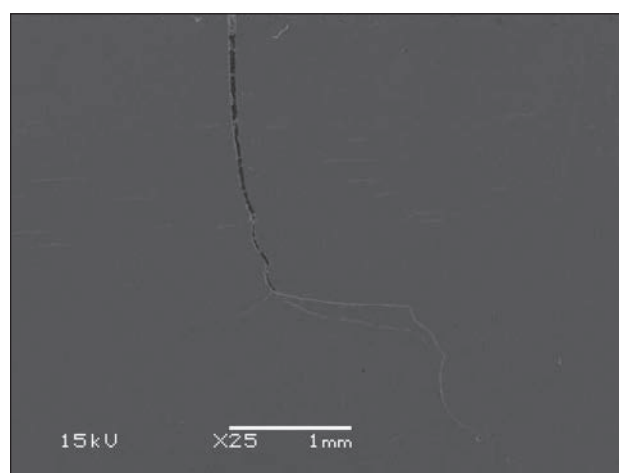
Water storage	Group	FS, MPa	FM, GPa
1 d	Group 1	100.8 $\pm$ 16.7 <sup>a</sup>	2.87 $\pm$ 0.32 <sup>ad</sup>
	Group 2	75.4 $\pm$ 10.1 <sup>bd</sup>	2.16 $\pm$ 0.22 <sup>b</sup>
	Group 3	98.7 $\pm$ 12.3 <sup>ac</sup>	3.13 $\pm$ 0.59 <sup>acd</sup>
	Group 4	93.5 $\pm$ 10.1 <sup>ace</sup>	2.69 $\pm$ 0.25 <sup>a</sup>
30 d	Group 1	70.5 $\pm$ 6.5 <sup>bd</sup>	2.51 $\pm$ 0.28 <sup>bcd</sup>
	Group 2	62.2 $\pm$ 9 <sup>b</sup>	2.29 $\pm$ 0.40 <sup>bc</sup>
	Group 3	92.1 $\pm$ 6.8 <sup>ace</sup>	2.76 $\pm$ 0.29 <sup>acd</sup>
	Group 4	81.3 $\pm$ 9.7 <sup>de</sup>	2.67 $\pm$ 0.23 <sup>acd</sup>
One-way ANOVA (P value)		< .001	< .001

The same superscript lowercase letters indicate groups not statistically significantly different when compared using Tukey multiple comparisons post hoc analysis ( $P > .05$ ).

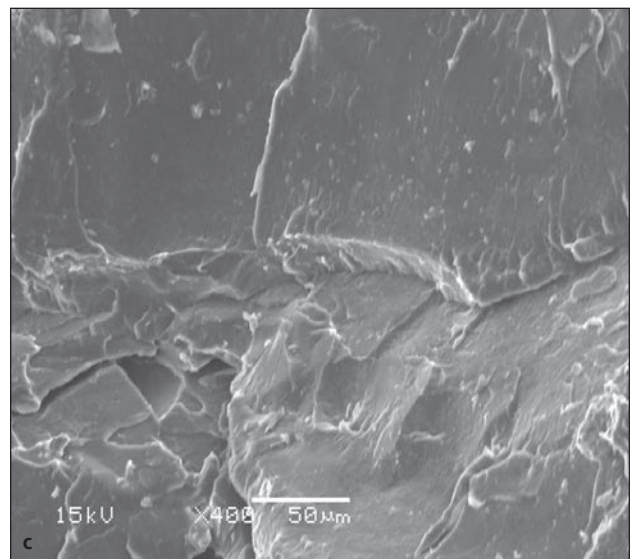
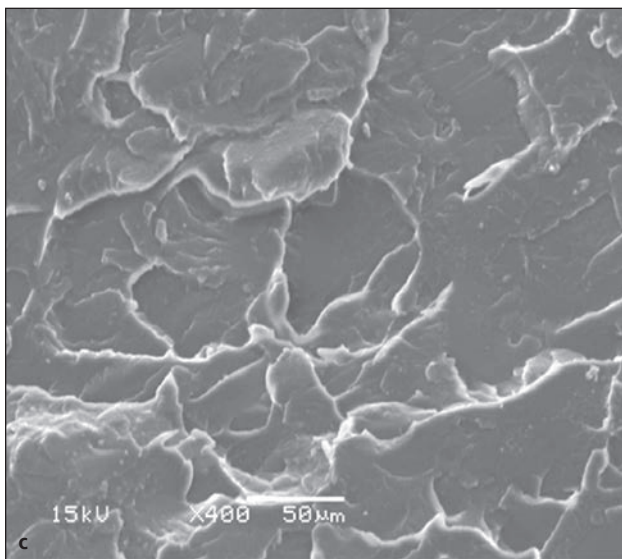
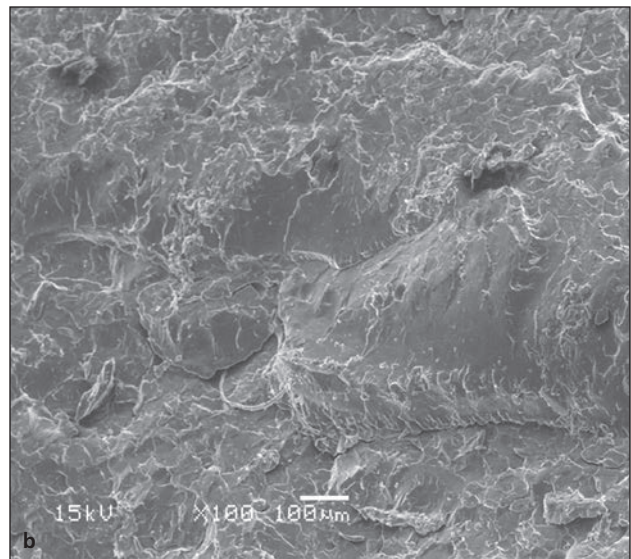
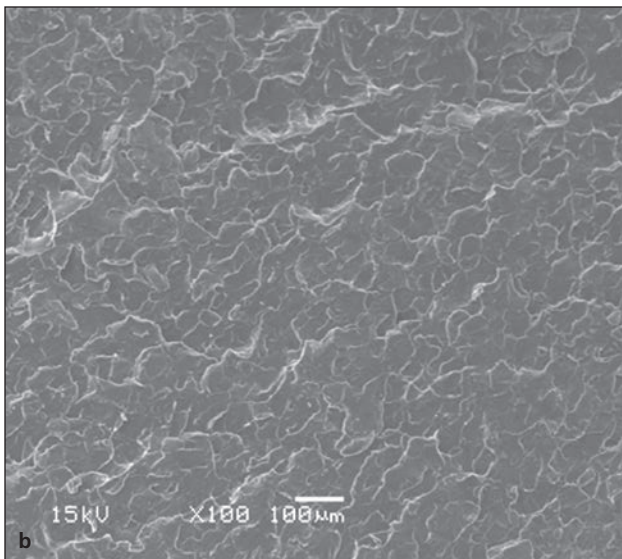
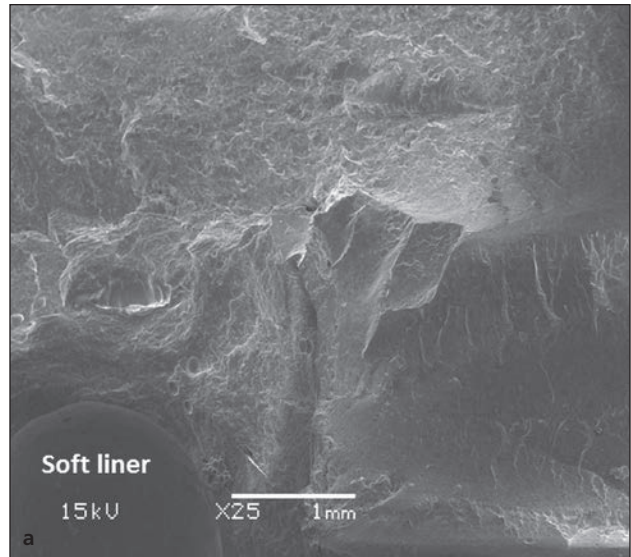
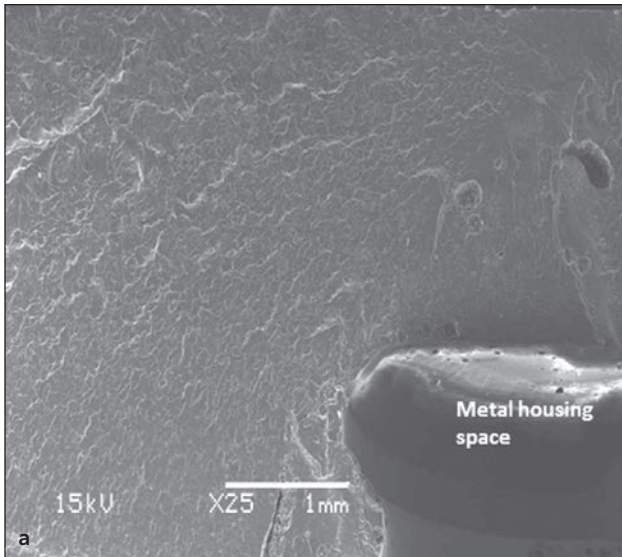
**Table 2** Fracture Mode of Test Specimens

Group	Fracture arrested at fibers (incompletely fractured)		Specimens fractured into pieces	
	1-d water storage	30-d water storage	1-d water storage	30-d water storage
1	–	–	10/10	10/10
2	–	–	10/10	10/10
3	1/10	2/10	9/10	8/10
4	–	–	10/10	10/10

Values are presented as n/total.

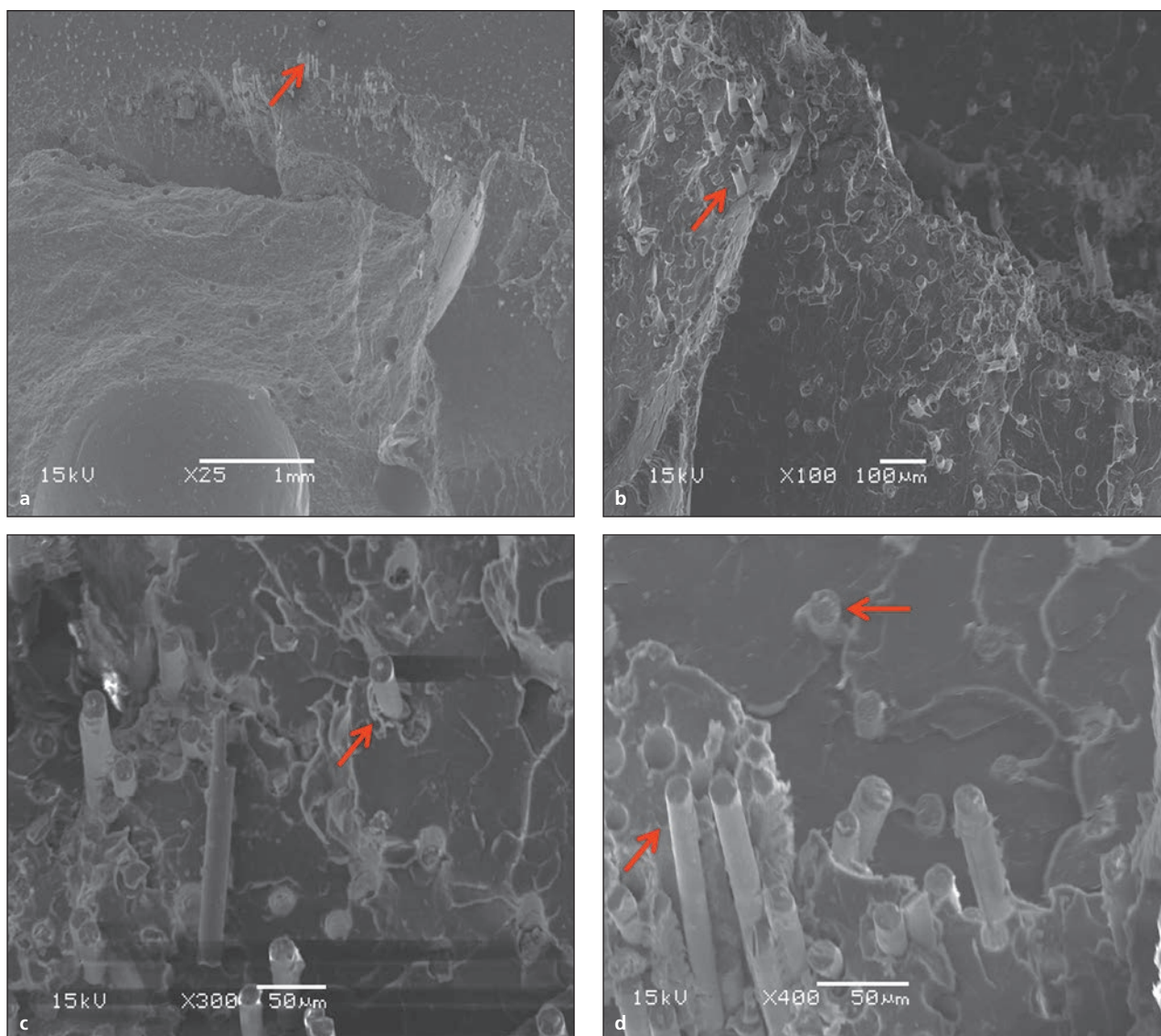


**Fig 4** Scanning electron photomicrograph of a fracture line for an incompletely fractured test specimen in group 3.



**Fig 5** Scanning electron photomicrographs of fractured surfaces in group 1 at (a)  $\times 25$ , (b)  $\times 100$ , and (c)  $\times 400$  magnifications.

**Fig 6** Scanning electron photomicrographs of fractured surfaces in group 2 at (a)  $\times 25$ , (b)  $\times 100$ , and (c)  $\times 400$  magnifications.

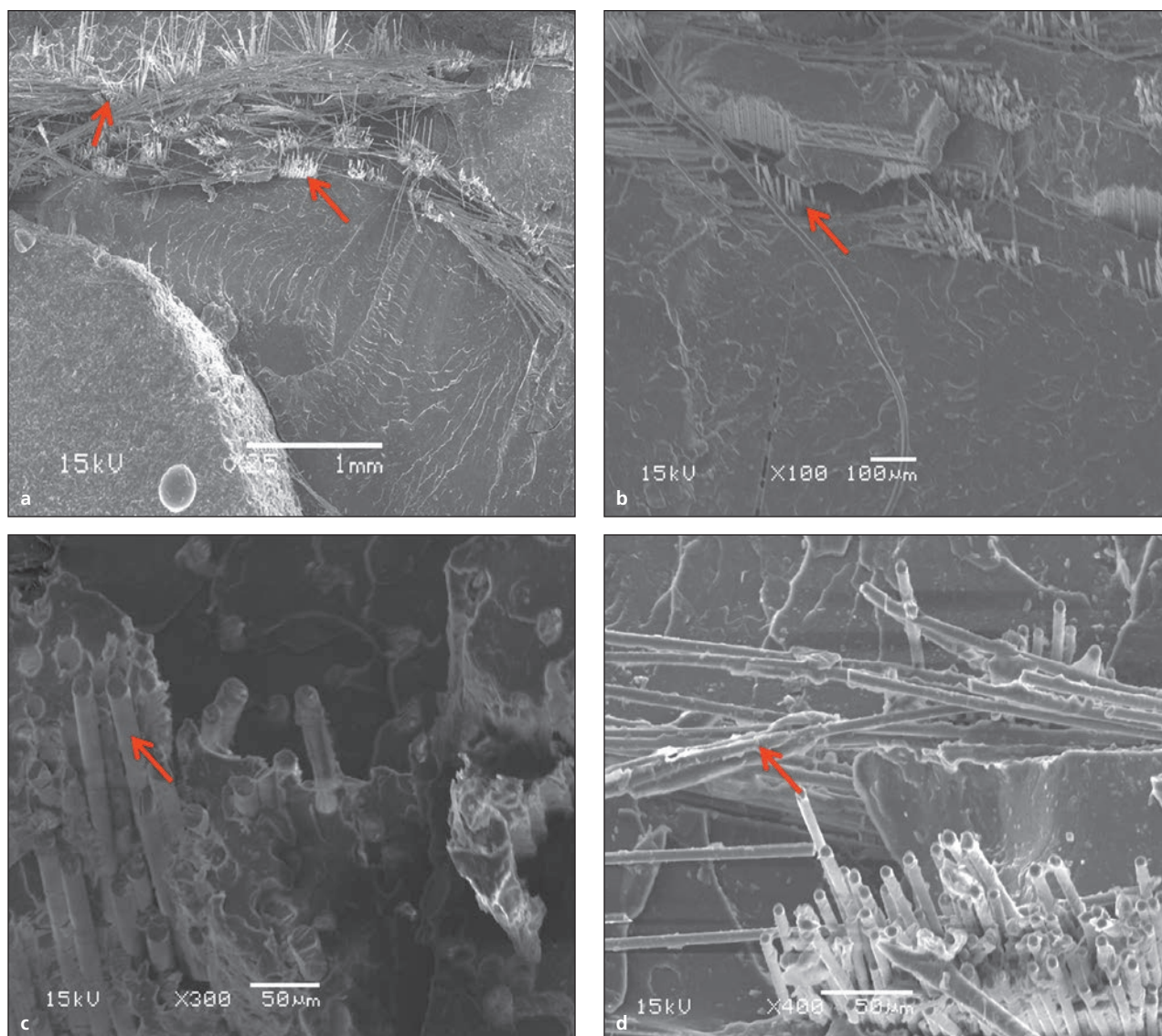


**Fig 7** Scanning electron photomicrographs of fractured surfaces in group 3 at (a)  $\times 25$ , (b)  $\times 100$ , (c)  $\times 300$ , and (d)  $\times 400$  magnifications. Red arrows represent fibers.

content would increase the tensile bond strength of silicone soft liners to the base material. This was supported by the SEM evaluation (Fig 9). A previous study also concluded that water aging for 12 weeks did not affect the bond strength of silicone-based soft liners to the denture base resin.<sup>49</sup>

Fiber reinforcement placed above the attachment significantly increased the flexural strength<sup>24,26</sup> and fatigue resistance<sup>25</sup> of locator-retained overdentures. These fibers tend to stretch and absorb more energy before allowing fracture to occur when placed closer to the tensile stress side.<sup>50</sup> This explains the high fracture strength values of groups 3 and 4 when compared to group 2 under both storage conditions. The efficiency of fiber

reinforcement (Krenchel factor) is dependent on different factors, such as the quantity of fibers within the polymer matrix,<sup>29</sup> fiber length,<sup>31</sup> form,<sup>28</sup> orientation,<sup>51</sup> adhesion to the matrix polymer,<sup>52</sup> impregnation with the polymer matrix,<sup>28</sup> and fiber location.<sup>24</sup> Continuous unidirectional fibers are anisotropic, with high strength and stiffness only in one direction. On the other hand, woven fibers are isotropic, reinforcing the polymer in two directions. The Krenchel factor is 1 for unidirectional fibers and 0.5 for the bidirectional ones.<sup>27</sup> The toughness of polymers in thin attachment areas for tooth-supported or implant-retained overdentures can be increased by adding glass-fiber reinforcement.<sup>53</sup> Therefore, the addition of fiber reinforcement on the top of the implant abutment can



**Fig 8** Scanning electron photomicrographs of fractured surfaces in group 4 at (a)  $\times 25$ , (b)  $\times 100$ , (c)  $\times 300$ , and (d)  $\times 400$  magnifications. Red arrows indicate fibers.

delay the onset of crack initiation and maximizes the force required for its growth.

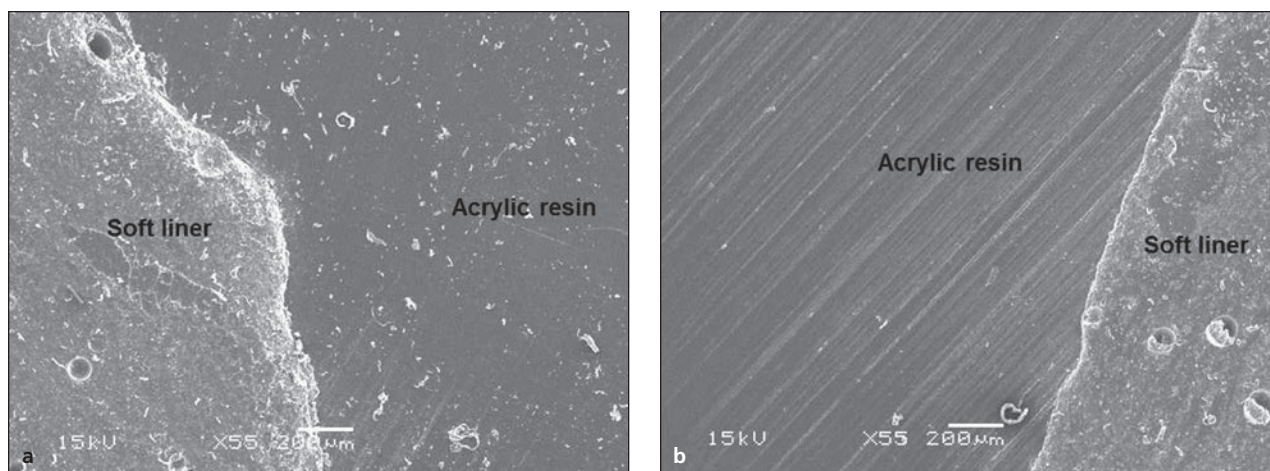
The *in vitro* model used for this study may not be exactly replicating the *in vivo* stresses and failure modes. Further studies are needed to evaluate and compare the mechanical properties of different types and thicknesses of ball-soft liner-retained overdentures and to investigate the reinforcing effect of using glass fibers under dynamic loading conditions.

## CONCLUSIONS

Within the limitations of this study, the following can be concluded:

- In contrast to overdentures retained with a metal matrix, the flexural strength and flexural modulus of overdentures retained with a silicone soft liner matrix were not significantly affected by water storage for 30 days.
- After 30 days of water storage, overdentures retained with metal matrices did not display significantly different flexural strength and modulus values when compared to those retained with silicone soft liner housing.
- Placing unidirectional and bidirectional glass-fiber reinforcement above soft liner matrices can increase the fracture resistance of ball-soft liner-retained overdentures.





**Fig 9** Scanning electron photomicrographs of bonding surfaces between the acrylic resin and soft liner after (a) 1 day and (b) 30 days of water storage.

## ACKNOWLEDGMENTS

The authors report no conflicts of interest.

## REFERENCES

1. Feine JS, Carlsson GE, Awad MA, et al. The McGill consensus statement on overdentures. Mandibular two-implant overdentures as first choice standard of care for edentulous patients. Montreal, Quebec, May 24–25, 2002. *Int J Oral Maxillofac Implants* 2002;17:601–602.
2. Nogueira TE, Dias DR, Leles CR. Mandibular complete denture versus single-implant overdenture: A systematic review of patient-reported outcomes. *J Oral Rehabil* 2017;44:1004–1016.
3. Amaral CF, Gomes RS, Rodrigues Garcia RCM, Del Bel Cury AA. Stress distribution of single-implant-retained overdenture reinforced with a framework: A finite element analysis study. *J Prosthet Dent* 2018;119:791–796.
4. Alqutaibi AY, Esposito M, Algabri R, et al. Single vs two implant-retained overdentures for edentulous mandibles: A systematic review. *Eur J Oral Implantol* 2017;10:243–261.
5. Trakas T, Michalakos K, Kang K, Hirayama H. Attachment systems for implant retained overdentures: A literature review. *Implant Dent* 2006;15:24–34.
6. Federick DR, Caputo AA. Effects of overdenture retention designs and implant orientations on load transfer characteristics. *J Prosthet Dent* 1996;76:624–632.
7. Duyck J, Van Oosterwyck H, Vander Sloten J, De Cooman M, Puers R, Naert I. In vivo forces on oral implants supporting a mandibular overdenture: The influence of attachment system. *Clin Oral Investig* 1999;3:201–207.
8. Büttel AE, Lüthy H, Sendi P, Marinello CP. Wear of ceramic and titanium ball attachments in subjects with an implant-retained overdenture: A controlled clinical trial. *J Prosthet Dent* 2012;107:109–113.
9. ELSyad MA, Errabti HM, Mustafa AZ. Mandibular denture base deformation with locator and ball attachments of implant-retained overdentures. *J Prosthodont* 2016;25:656–664.
10. Kanazawa M, Minakuchi S, Hayakawa I, Hirano S, Uchida T. In vitro study of reduction of stress transferred onto tissues around implants using a resilient material in maxillary implant overdentures. *J Med Dent Sci* 2007;54:17–23.
11. Cain JR, Mitchell DL. Soft liner-retained, implant-supported overdenture: A technical note. *Int J Oral Maxillofac Implants* 1998;13:857–860.
12. ELSyad MA, Shaheen NH, Ashmawy TM. Long-term clinical and prosthetic outcomes of soft liner and clip attachments for bar/implant overdentures: A randomised controlled clinical trial. *J Oral Rehabil* 2017;44:472–480.
13. Sakaguchi RL, Powers JM. *Craig's Restorative Dental Materials*. Philadelphia: Mosby Elsevier, 2012.
14. Adrian ED, Krantz WA, Ivanhoe JR. The use of processed silicone to retain the implant-supported tissue-borne overdenture. *J Prosthet Dent* 1992;67:219–222.
15. ELSyad MA. Prosthetic aspects and patient satisfaction with resilient liner and clip attachments for bar- and implant-retained mandibular overdentures: A 3-year randomized clinical study. *Int J Prosthodont* 2012;25:148–156.
16. Gibreel M, Fouad M, El-Waseef F, El-Amier N, Marzook H. Clips vs resilient liners used with bilateral posterior prefabricated bars for retaining four implant-supported mandibular overdentures. *J Oral Implantol* 2017;43:273–281.
17. Wikiewicz W, Kasperski J, Wikiewicz M, Miernik M, Król W. The adhesion of modern soft relining materials to acrylic dentures. *Adv Clin Exp Med* 2014;23:621–625.
18. Lassila LV, Mutluay MM, Tezvergil-Mutluay A, Vallittu PK. Bond strength of soft liners to fiber-reinforced denture-base resin. *J Prosthodont* 2010;19:620–624.
19. Hashem MI. Advances in soft denture liners: An update. *J Contemp Dent Pract* 2015;16:314–318.
20. Faot F, Costa MA, Del Bel Cury AA, Rodrigues Garcia RC. Impact strength and fracture morphology of denture acrylic resins. *J Prosthet Dent* 2006;96:367–373.
21. Gonda T, Ikebe K, Dong J, Nokubi T. Effect of reinforcement on overdenture strain. *J Dent Res* 2007;86:667–671.
22. Ozkır SE, Yılmaz B. Effect of different housing retaining materials on the flexural strength of an acrylic resin overdenture base. *J Prosthet Dent* 2017;118:500–503.
23. Domingo KB, Burgess JO, Litaker MS, McCracken MS. Strength comparison of four techniques to secure implant attachment housings to complete dentures. *J Prosthet Dent* 2013;110:8–13.
24. Gibreel M, Lassila LVJ, Närhi TO, Perea-Lowery L, Vallittu PK. Load-bearing capacity of simulated locator-retained overdenture system. *J Prosthet Dent* 2018;120:558–564.
25. Gibreel M, Lassila LVJ, Närhi TO, Perea-Lowery L, Vallittu PK. Fatigue resistance of a simulated single locator overdenture system. *J Prosthet Dent* 2019;122:557–563.
26. Fajardo RS, Pruitt LA, Finzen FC, Marshall GW, Singh S, Curtis DA. The effect of E-glass fibers and acrylic resin thickness on fracture load in a simulated implant-supported overdenture prosthesis. *J Prosthet Dent* 2011;106:373–377.
27. Vallittu PK. An overview of development and status of fiber-reinforced composites as dental and medical biomaterials. *Acta Biomater Odontol Scand* 2018;4:44–55.
28. Vallittu PK. Flexural properties of acrylic resin polymers reinforced with unidirectional and woven glass fibers. *J Prosthet Dent* 1999;81:318–326.

29. Vallittu PK, Lassila VP, Lappalainen R. Acrylic resin-fiber composite—Part I: The effect of fiber concentration on fracture resistance. *J Prosthet Dent* 1994;71:607–612.
30. Gurbuz O, Dikbas I, Unalan F. Fatigue resistance of acrylic resin denture base material reinforced with E-glass fibres. *Gerodontology* 2012;29:e710–e714.
31. Karacaer O, Polat TN, Tezvergil A, Lassila LVJ, Vallittu PK. The effect of length and concentration of glass fibers on the mechanical properties of an injection- and a compression-molded denture base polymer. *J Prosthet Dent* 2003;90:385–393.
32. Salloum AM. Creep and stress relaxation behavior of two soft denture liners. *J Indian Prosthodont Soc* 2014;14:93–97.
33. ISO 20795-1:2013. Dentistry—Base polymers—Part 1: Denture base polymers. Geneva: International Organization for Standardization, 2013.
34. Zmudzki J, Chladek W. Elastic silicone matrices as a tool for load relief in overdenture implants. *Acta Bioeng Biomech* 2008;10:7–14.
35. Abe Y, Taji T, Hiasa K, Tsuga K, Akagawa Y. Dynamic viscoelastic properties of vinyl polysiloxane denture soft lining materials. *J Oral Rehabil* 2009;36:887–893.
36. Jepson NJ, McCabe JF, Storer R. Age changes in the viscoelasticity of permanent soft lining materials. *J Dent* 1993;21:171–178.
37. Murata H, Hamada T, Sadamori S. Relationship between viscoelastic properties of soft denture liners and clinical efficacy. *Jap Dent Sci Rev* 2008;44:128–132.
38. Yoshida K, Takahashi Y, Sasaki H, Hamanaka I, Kawaguchi T. Flexural strengths of reinforced denture base resins subjected to long-term water immersion. *Acta Biomater Odontol Scand* 2016;2:20–24.
39. Vallittu PK, Miettinen V, Alakujjala P. Residual monomer content and its release into water from denture base materials. *Dent Mater* 1995;11:338–342.
40. Arima T, Hamada T, McCabe JF. The effects of cross-linking agents on some properties of HEMA-based resins. *J Dent Res* 1995;74:1597–1601.
41. Takahashi Y, Chai J, Kawaguchi M. Equilibrium strengths of denture polymers subjected to long-term water immersion. *Int J Prosthodont* 1999;12:348–352.
42. Vallittu PK. Effect of 180-week water storage on the flexural properties of E-glass and silica fiber acrylic resin composite. *Int J Prosthodont* 2000;13:334–339.
43. Elysyad MA, El-Waseef FA, Al-Mahdy YF, Fouad MM. A comparison of mandibular denture base deformation with different impression techniques for implant overdentures. *Clin Oral Implants Res* 2013;24(suppl A100):127–133.
44. Ikeda T, Wakabayashi N, Ona M, Ohyama T. Effects of polymerization shrinkage on the interfacial stress at resin-metal joint in denture-base: A non-linear FE stress analysis. *Dent Mater* 2006;22:413–419.
45. Shaygan F, Khan Z, Gettleman L. Retention and longevity of resilient denture liners in implant overdentures. *J Dent Res* 1993;72:272.
46. Murat H, Taguchi N, Hamada T, McCabe JF. Dynamic viscoelastic properties and the age changes of long-term soft denture liners. *Biomaterials* 2000;21:1421–1427.
47. Rodrigues S, Shenoy V, Shetty T. Resilient liners: A review. *J Indian Prosthodont Soc* 2013;13:155–164.
48. McCabe JF, Carrick TE, Kamohara H. Adhesive bond strength and compliance for denture soft lining materials. *Biomaterials* 2002;23:1347–1352.
49. El-Hadary A, Drummond JL. Comparative study of water sorption, solubility, and tensile bond strength of two soft lining materials. *J Prosthet Dent* 2000;83:356–361.
50. Kanie T, Fujii K, Arikawa H, Inoue K. Flexural properties and impact strength of denture base polymer reinforced with woven glass fibers. *Dent Mater* 2000;16:150–158.
51. Basant G, Reddy YG. The effect of incorporation, orientation and silane treatment of glass fibers on the fracture resistance of interim fixed partial dentures. *J Indian Prosthodont Soc* 2011;11:45–51.
52. Vallittu PK. The effect of void space and polymerization time on transverse strength of acrylic-glass fibre composite. *J Oral Rehabil* 1995;22:257–261.
53. Dyer SR, Lassila LVJ, Jokinen M, Vallittu PK. Effect of cross-sectional design on the modulus of elasticity and toughness of fiber-reinforced composite materials. *J Prosthet Dent* 2005;94:219–226.

## Literature Abstract

### Comprehensive Analysis of Risk Factors for Periodontitis Focusing on the Saliva Microbiome and Polymorphism

Few studies have exhaustively assessed the relationships among polymorphisms, the microbiome, and periodontitis. The objective of the present study was to assess associations simultaneously among polymorphisms, the microbiome, and periodontitis. Propensity score matching was used with a 1:1 ratio to select subjects, and then 22 individuals (mean  $\pm$  SD age = 60.7  $\pm$  9.9 years) were analyzed. After saliva collection, V3-4 regions of the 16S rRNA gene were sequenced to investigate microbiome composition, alpha diversity (Shannon index, Simpson index, Chao1, and abundance-based coverage estimator), and beta diversity using principal coordinate analysis (PCoA) based on weighted and unweighted UniFrac distances. A total of 51 single-nucleotide polymorphisms (SNPs) related to periodontitis were identified. The frequencies of SNPs were collected from Genome-Wide Association Study data. The PCoA of unweighted UniFrac distances showed a significant difference between the periodontitis and control groups ( $P < .05$ ). There were no significant differences in alpha diversity or PCoA of weighted UniFrac distance ( $P > .05$ ). Two families (*Lactobacillaceae* and *Desulfobulbaceae*) and one species (*Porphyromonas gingivalis*) were observed only in the periodontitis group. No SNPs showed significant expression. These results suggest that periodontitis was related to the presence of *P. gingivalis* and the families *Lactobacillaceae* and *Desulfobulbaceae*, but not SNPs.

Toyama N, Ekuni D, Matsui D, et al. *Int J Environ Res Public Health* 2021;18:6430. References: 36. Reprints: pu171qxi@s.okayama-u.ac.jp —David Ojcius, USA